

Modelo: BLE100 1GHz	ESPECIFICACIONES TECNICAS	
Fecha: 2013		
Hojas 1 de 1		
Asunto	Line Extender 1GHz.	

## BLE100 1 GHz Line Extender

STARLINE® Series



Motorola's 1 GHz STARLINE® Series Broadband Line Extender, model BLE100\*, leads the industry in features and performance and is designed to meet the needs of today's expanding broadband communication networks. This two-way capable single output amplifier offers high gain, high output levels, ergonomics, superior distortion performance, multiple diplex filter options, 16 dB return loss, and Bode equalization. The BLE100 also allows optional advanced features such as ingress control switching and status monitoring.

### ENHANCED GALLIUM ARSENIDE

The BLE100 uses Enhanced Gallium Arsenide (E-GaAs) hybrids. This second generation technology provides superior distortion performance in CTB and CSO over the standard GaAs technology. Compared to silicon and competing GaAs technology, E-GaAs distortion performance remains linear at significantly higher output levels. This higher output level allows the customer to maximize system performance and reduce system costs. We encourage our customers to contact their Motorola Account Representative to determine the optimal levels for their systems.

### HIGH GAIN

The BLE100 also offers high gain, which allows the operator to hold existing amplifier locations during system upgrades thereby reducing system costs such as maintenance, installation and powering.

**The BLE100 two-way line extender offers 1 GHz bandwidth capability, high gain, high output level, ergonomics, and superior distortion performance with the option to bench upgrade to N-split (5-85/104-1003 MHz) in the future.**

### BENEFITS INCLUDE:

- 1003 MHz Enhanced Gallium Arsenide (E-GaAs) power doubling technology
- High gain
- High output level
- Multiple diplex filter frequency split options
- Future N-split (5-85/104-1003 MHz) availability
- Ease-of-use ergonomics
- 16 dB return loss
- 60/90 V powering
- Meets Telcordia GR-1098-Core voltage surge requirements using surge waveforms as described in IEEE C62.41
- FCC, CENELEC and CCC approved
- RoHS compliant models available Q1 2007
- Bode equalization (thermal or auto controlled)
- 15 Ampere AC capability
- Optional return path ingress control and status monitor
- Directional coupler –20 dB test points



## BACKWARD COMPATIBILITY

The reversible BLE100 electronics package can be made backward compatible with the STARLINE JLX and 10-Amp BLE housing by installing the BLE-15A Kit. This kit contains 50 mil gold plated platform assemblies. This makes it possible for the amplifier to carry 15 Amperes continuous through the input or output ports. There is also a "low current" (10A) option that can be ordered for the electronics module (no housing included), which is backward compatible with the STARLINE JLX and 10-Amp BLE housing, without the use of a kit.

If an "electronics only" package is ordered, it will include the deeper housing cover to accommodate ergonomic accessories. *Note: this is not the deeper housing cover associated with the status monitor. When ordering the status monitor option, a deep housing cover is also required.*

## FORWARD PATH

The operational gain of the BLE100 is 34 dB, with 16 dB return loss. Output level control is achieved through the use of an interstage Bode equalizer, which compensates for coaxial cable attenuation changes due to temperature. Equalization may be controlled manually, with a thermal drive unit (TDU), or with a single pilot closed loop automatic drive unit, model ADU-\* (analog pilot) or QADU-\* (QAM pilot). Both the ADU and QADU boards are common to the STARLINE family of amplifiers (with the exception of the SLE). ADUs utilize Surface Acoustic Wave (SAW) filters for determining pilot frequency. This improves amplifier stability over temperature.

To further ensure system flexibility, installation ease and maintenance, the amplifier is engineered for compatibility with standard accessories, such as attenuators, equalizers, ADUs or QADUs, return amplifiers, automotive fuses and FTEC crowbar circuits.

The BLE100 uses modular diplex filters, which can be changed for a different frequency split as required. The amplifier is available with S-split filters for a 5-40 MHz return and a 52-1003 MHz forward band. K-splits (5-42 MHz/54-1003 MHz), J-splits (5-55 MHz/70-1003 MHz), and A-splits (5-65 MHz/85-1003 MHz) are also available. The N-split (5-85 MHz/104-1003 MHz) option is currently in development. These same filters can be used for all US-style Motorola RF distribution amplifiers (models BLE, MB/MBE, BT).

## RETURN PATH

High gain return amplifier kits can be ordered which provide 24 dB minimum station gain. Return path equalizers from 0 to 12 dB can be customer selected. Optional features include thermal compensation and ingress control switching. Thermal compensation comes in the form of a plug-in JXP-TH°C, which stabilizes gain and match over temperature extremes.

Also available is Ingress Control Switching (ICS) in 3 states. This pin diode attenuator circuit can lower levels by 6 dB or by 38 dB with a controlled slew rate for minimum bit errors. The LIFELINE® Broadband Line Extender transponder (available directly from AM Networks) and accompanying deeper housing lid are required to operate the Ingress Control Switch from a remote location.

## Model Availability

To reduce customer costs and to accommodate customer specific needs, the STARLINE BLE100 can be ordered in a variety of different models. *Please refer to the BLE100 ordering information below for options.*

# BLE100 Specifications

*All specifications stated as worst-case over temperature unless otherwise noted.*

**STARLINE®**

Single Output Line Extender

Enhanced Gallium Arsenide

## BLE100S SPECIFICATIONS

1 GHz Broadband Line Extender

PARAMETER	UNITS	NOTE	FORWARD	RETURN RA-KIT/H	
Passband	MHz	1	52-1003	5 - 40	
Flatness	dB	2	± 0.70	± 0.50	
Minimum Full Gain	dB	3	38	NA	
Operational Gain	dB	4	34	24	
Manual Bode Slope Control Range	dB	5	± 4.0	NA	
Interstage Equalizer Slope	dB	6	9 ± 1	NA	
Noise Figure - 40/52/870/1003 MHz	dB	7	NA / 8 / 8 / 8	5.5 / NA / NA	
Reference Frequency	MHz	8	1003 / 550 / 52		
Output Level	dBmV		45 / 44 / 37	35 flat	
Channel Loading	NTSC		79	6	
Compressed data loading	MHz	20	450	NA	
Distortion	CTB	dBc	9,19,21	76	80
	XM	dBc	10,19	70	70
	CSO	dBc	9,11, 19	71	81
Test Point (all)	dB	13	20 ± 1.0	20 ± 1.0	
Return Loss	dB	14	15	15	
Hum Modulation @ 12A	dBc	14	70 (52 - 900 MHz)	80 (5 - 10 MHz)	
			65 (901 - 1003 MHz)	70 (11 - 40 MHz)	
Hum Modulation @ 15A	dBc	14	65 (52 - 900 MHz)	55 (5 - 10 MHz)	
			60 (901 - 1003 MHz)	65 (11 - 40 MHz)	
DC Voltage	VDC	15	+ 24.0 ± 0.25		
Current DC	mA	16	800	925	
DC Ripple	mV		15 P-P		
Power Consumption	W		22.6	26.6	
AC Input Voltage Range	VAC		38 - 90		
AC Current Draw	A	17	Forward Only		
			@90 VAC	0.48	0.56
			@75 VAC	0.50	0.59
			@60 VAC	0.56	0.65
			@53 VAC	0.60	0.70
			@45 VAC	0.67	0.78
			@38 VAC	0.75	0.88
AC Bypass Current	A	17	15 (or 10 amp option)		
Group Delay, Typical	nSec	18	55.25 to 58.83 MHz	32	NA
			61.25 to 64.83 MHz	9	NA
			67.25 to 70.83 MHz	5	NA
			77.25 to 80.83 MHz	2	NA
			5.0 to 6.5 MHz	NA	45
			10.0 to 11.5 MHz	NA	10
			33.5 to 35.0 MHz	NA	12
			38.5 to 40.0 MHz	NA	35
Housing Dimensions			10.6" L x 8.0" W x 4.7" D	26.9cm x 20.3cm x 11.9 cm	
Weight			7.2 lbs	3.2 kg	
Ambient Operating Temperature			-40° to +140° F	-40° to +60° C	

**Specification Notes:**

- Operating passband of station. Diplex filters are plugged into the electronic chassis.
- Referenced to the average gain across the stated passband.
- Minimum full gain at 1003 MHz includes loss of equalizer but Bode slope reserves have not been set. Return gain includes loss of GRE-4 return equalizer.
- Operational gain includes loss of slope reserves as well as equalizer.
- Amount of Bode slope control range from midpoint (typical setting is -4 dB at 1003 MHz @ 20°C). This control should not be used for gain reduction.
- Amount of slope created and cable equivalence of fixed interstage equalizer. Interstage equalizer is a plug-in.
- Noise Figure is specified at room temperature at the cable entry facility of the housing and includes the loss of 1 dB for the pre-stage equalizer. The return Noise Figure includes the station loss preceding the RF hybrid. The noise figure from Fmin to 870 MHz over temperature is 8.5 dB worst-case and from Fmin to 1003 MHz is 9 dB worst-case.
- Frequencies that relate the picture carriers or passband edges to the specified output levels and tilts.
- Measured with CW carriers and spectrum analyzer over specified temperature range. References the worst-case channel. Specifications are compliant with the test methods as stated in NCTA RECOMMENDED PRACTICES FOR MEASUREMENTS ON CABLE TELEVISION SYSTEMS.
- Measured with wave analyzer and synchronous, 100% depth modulated channels. References the worst-case channels over specified temperature range. Specifications are compliant with the test methods as stated in NCTA RECOMMENDED PRACTICES FOR MEASUREMENTS ON CABLE TELEVISION SYSTEMS.
- Composite Second Order distortion refers only to those beat clusters that fall +0.75 MHz and +1.25 MHz above the subject picture carrier. CSO beat clusters that have a -0.75 MHz and -1.25 MHz relationship to the subject picture carrier are not included in this specification.
- Test points should be used with GFAL adaptor.
- Match measurement at the station input and output, cable-entry facilities, at the specified passbands for operational gain.
- Measured with the stated AC Bypass Current.
- Measured at the power connector.
- Current draw at +24.0 VDC.
- AC current is stated in RMS continuous. A 10-amp compatible electronics package is also available for installing into older 10-amp housings during upgrades.
- Group Delay is specified for standard NTSC video, where delay is the delta from picture carrier to 3.58 MHz color subcarrier. Reverse delay is in a 1.5 MHz bandwidth.
- Distortion numbers are worst case over temperature in a cascade.
- The compressed data loading is QAM carriers and are -6 dB relative to the analog CW carriers.
- CTB (Composite Triple Beat). At the specified channel loading, Enhanced Gallium Arsenide performance varies on a two point three-for-one (2:3:1) basis with amplifier output level.

# BLE100 Block Diagram

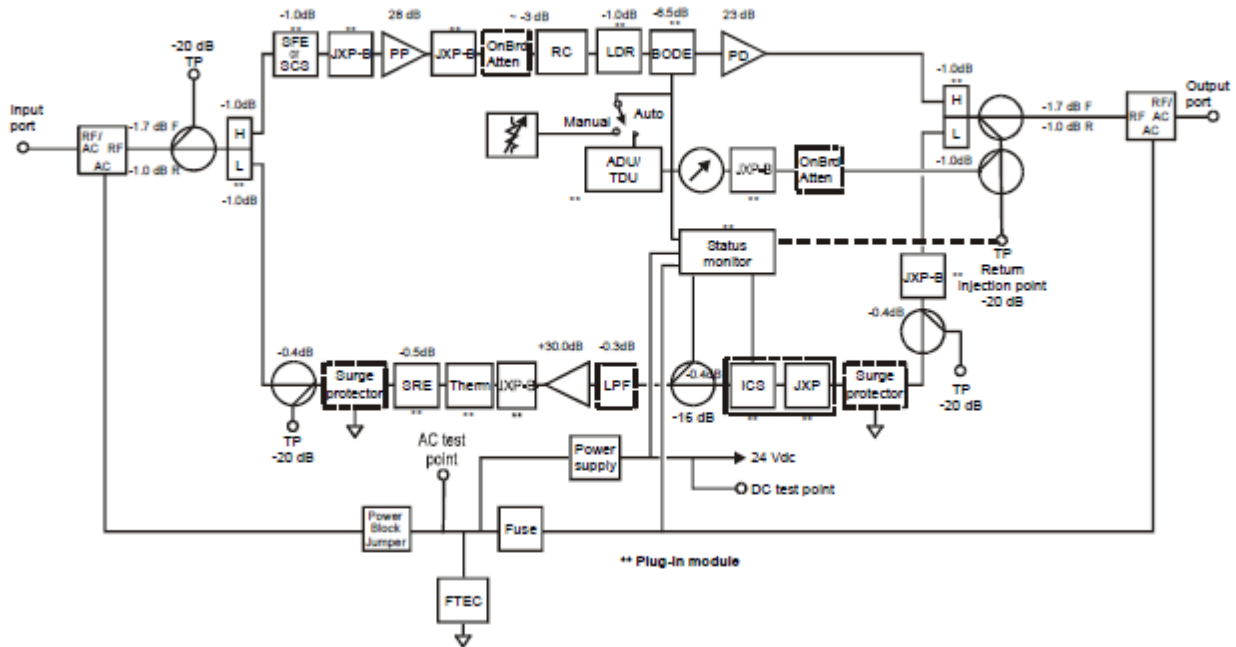

## 1 GHz BLE Ordering Guide

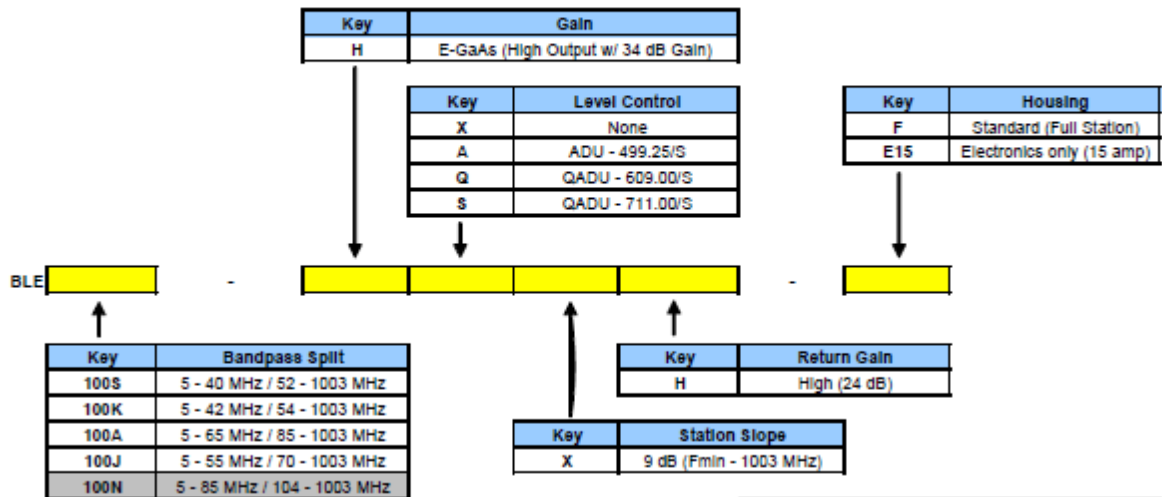

Key: Future options (not available today)